

ITEM #: _____ QTY: _____
 MODEL #: _____
 PROJECT NAME: _____

040921

3601 S. Banker St. Effingham, IL 62401 • Ph: (888) 431-2667 • Fax: (800) 433-2667

"UBBSS" UNDERBAR BLENDER SHELF



STANDARD FEATURES:

- ALL 18 GAUGE STAINLESS STEEL CONSTRUCTION
- TYPE 300 STAINLESS STEEL WITH #4 POLISH, SATIN FINISH
- 2" DIAMETER RUBBER GROMMET FOR POWER CORD ACCESS

SPECIFICATIONS:

- MATERIALS:
 - TOP: 18 GAUGE TYPE 300 STAINLESS STEEL
- MOUNTING OPTIONS:
 - BOLT TO FRONT OF APRON
- NSF CERTIFIED



BLENDER SHELF

MODEL #	LENGTH (L)	WT. (LBS)
UBBSS-12	12"	4
UBBSS-18	18"	5

DETAILED SPECIFICATIONS

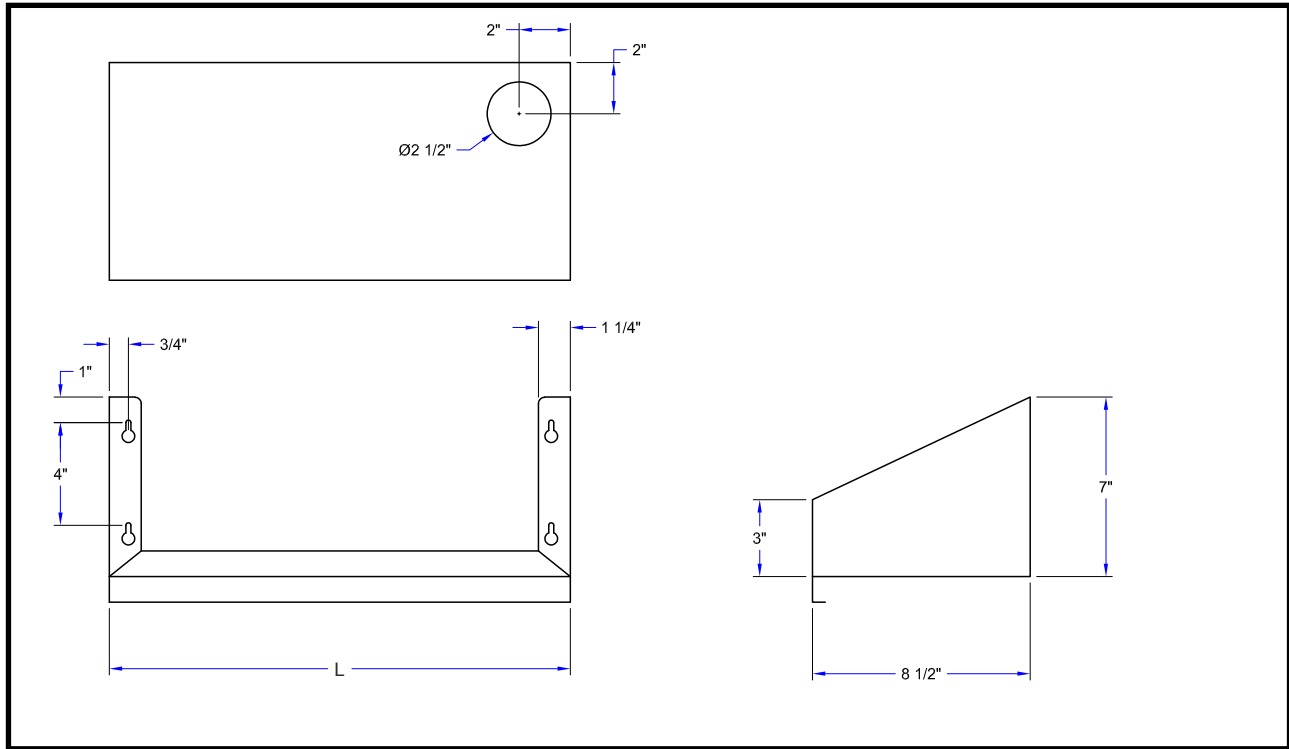

BLENDER SHELF

MODEL #	LENGTH (L)	WT. (LBS)
UBBSS-12	12"	4
UBBSS-18	18"	5

SOME UNITS SHIP UNASSEMBLED FOR REDUCED SHIPPING COST. ALL DIMENSIONS ARE TYPICAL. TOLERANCE +/- .500"
 John Boos & Co. is constantly engaged in a program of improving products and therefore reserves the right to change specifications without prior notice.



3601 S. Banker St. • Effingham, IL 62401 • quotes@johnboos.com

www.johnboos.com